

actual size

# Quartz Crystal · MQ5 (UM-5)

Pin Type Crystal · 7.7 x 3.1 mm

- high frequency stability
- wave soldering temperature: 260 °C max.
- package height 6.0 mm max.



## General Data

type	MQ5 (UM-5)
frequency range	10.0 ~ 40.0 MHz (fund. AT-cut)
	30.0 ~ 105.0 MHz (3rd OT AT-cut)
	50.0 ~ 175.0 MHz (5th OT AT-cut)
	70.0 ~ 250.0 MHz (7th OT AT-cut)
frequency tolerance at 25 °C	± 5 ppm ~ ± 30 ppm
load capacitance $C_L$	8 pF ~ 32 pF or series
shunt capacitance $C_0$	< 7 pF
storage temperature	-55 °C ~ +125 °C
drive level max.	500 $\mu$ W (100 $\mu$ W recommended)
aging	< ± 3 ppm first year

## Dimensions

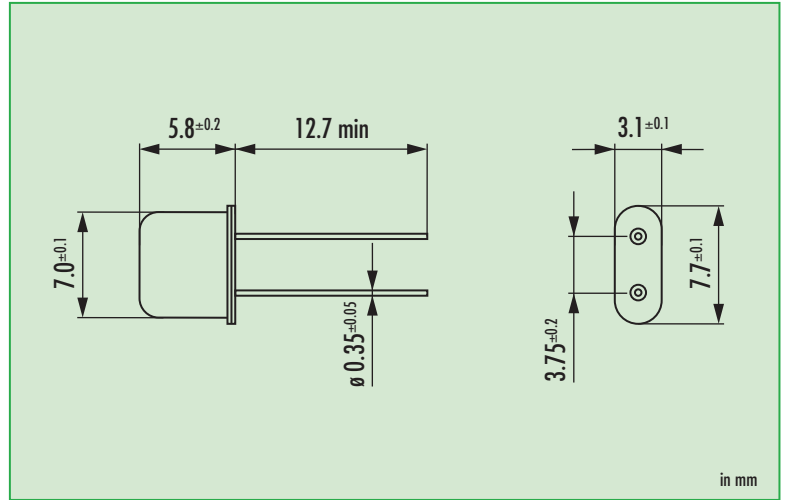

## Frequency Stability vs. Temperature

		± 3 ppm	± 5 ppm	± 10 ppm	± 30 ppm	± 50 ppm	± 100 ppm
0 °C ~ +60 °C		○	○	○			
-20 °C ~ +70 °C	STD.		○	○	●		
-40 °C ~ +85 °C	T1			○*	○	●	
-40 °C ~ +90 °C	T4				○	○	○
-40 °C ~ +105 °C	T2				○	○	○
-40 °C ~ +125 °C	T3						○

● standard  
○ available

\* ± 15 ppm, for  $f \leq 17$  MHz

## ESR (series resistance $R_s$ )

frequency in MHz	vibration mode	ESR max. in $\Omega$	ESR typ. in $\Omega$
10.0 ~ 19.999	fund.- AT	60	40
20.0 ~ 40.000	fund.- AT	40	20
30.0 ~ 79.999	3rd OT - AT	100	50
80.0 ~ 105.00	3rd OT - AT	80	40
50.0 ~ 59.999	5th OT - AT	250	150
60.0 ~ 129.99	5th OT - AT	200	100
130.0 ~ 175.0	5th OT - AT	180	120
70.0 ~ 129.99	7th OT - AT	250	180
130.0 ~ 250.0	7th OT - AT	200	150

## Order Information

Q	frequency	type	load capacitance in pF	stability at 25 °C	stability vs. temp. range	option
Quartz	10.0 ~ 250.0 MHz	MQ5	8 pF ~ 32 pF S for series	± 5 ~ ± 30 ppm	see table	blank = -20 °C ~ + 70 °C T1 = -40 °C ~ + 85 °C T2 = -40 °C ~ +105 °C T3 = -40 °C ~ +125 °C T4 = -40 °C ~ + 90 °C FU = for fundamental frequencies $\geq 20$ MHz 30T = 3rd overtone 50T = 5th overtone 70T = 7th overtone LL = lead length in mm PT = plastic tray

Example: Q 30.0-MQ5-30-5/30-FU (Suffix LF = RoHS compliant / Pb free pins or pads)

